

RECOMMENDED P.C.B. LAYOUT

SPECIFICATIONS

Electrical:

1. Rating: 20 V, 3.0 A for VBUS, 1.25A for GND
0.25A for other

2. Dielectric Withstand Voltage: 100V AC

3. Contact Resistance: 40 mΩ Max

4. Insulation Resistance: 100 MΩ Min

Mechanical:

1. Connector Mate and Unmate Force

1.1 Mate force: 5~20 N

1.2 Unmate force: 8~20 N

Material:

1. Housing: LCP

2. Contact: COPPER ALLOY

3. Shell: SUS

Finish:

1. Contact: Plated Gold in Mating Area ;

Tin Plated on Solder Balls ;

Nickel under plated overall

2. Shell: Nickel under Plated surface layer

B12	GND
B9	VBUS
B5	CC2
A5	CC1
A9	VBUS
A12	GND
PIN	SIGNAL NAME

RoHS Compliant

TOLERANCES ARE

MORETHANALL
PCB CONNECTORS
Cable ASSEMBLIES

煜倫股份有限公司

www.morethanall.com

DRAWING BY CY

CHECKED BY GENIUS

UNIT / mm SCALE 1 : 1

DATE

SIZE A4

PJECTION

Up to 5 ±0.2
Above 5 ~ 15 ±0.3
Above 15 ~ 30 ±0.4
Above 30 ~ 50 ±0.5
Angle ±0.3°



ORDER INFORMATION

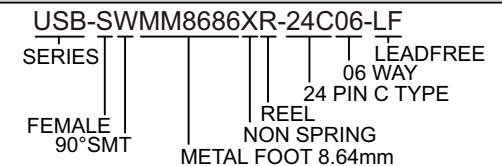

DESCRIPTION: USB C TYPE 2.0 Female SMT 6PIN

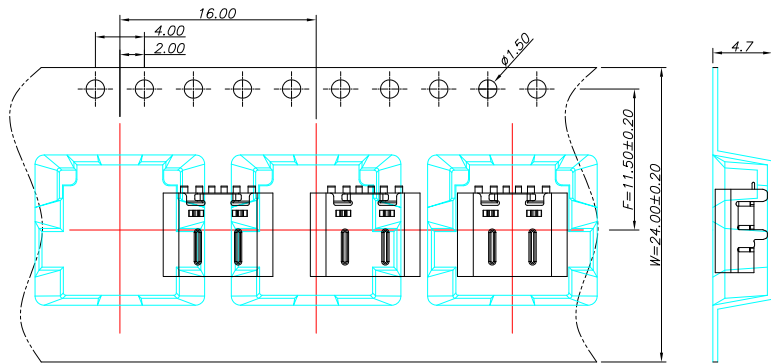

① 產品入載帶示意圖

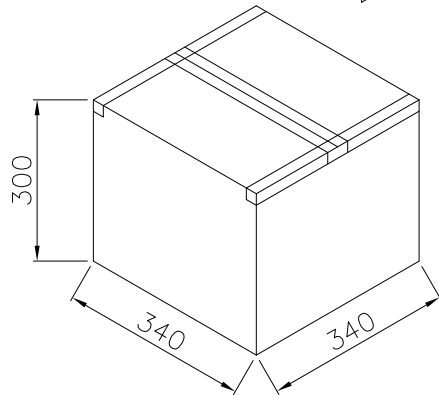

⑤ 外箱封箱示意圖

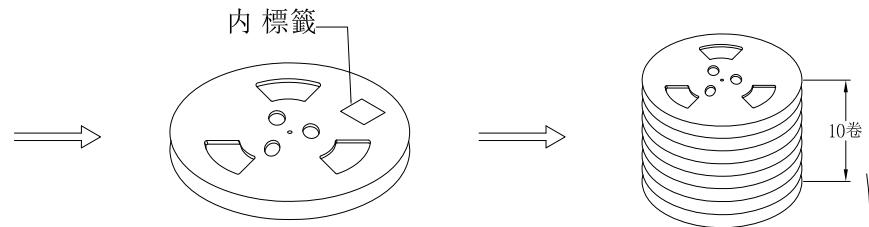

② 卷盤貼標籤示意圖

③ 10盤產品疊層示意圖

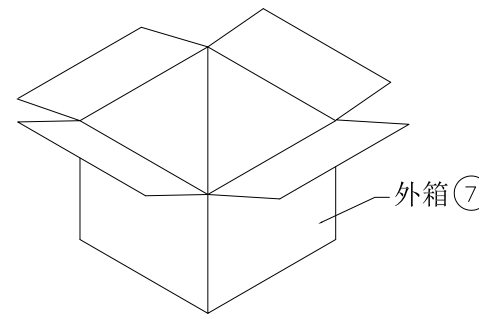

④ 產品入外箱示意圖

圖四

包裝說明:

1. 將檢驗好的成品;SMT朝下放入載帶底部;每卷裝1000PCS產品;具體如圖一所示
2. 將包裝好的產品;每盤必需貼上內標籤;具體如圖二所示
3. 將貼好內標籤的產品每10盤疊;具體如圖三圖四所示
4. 裝好後並封好紙箱及貼好相關標籤;具體如圖六所示;
(產品包裝的標籤,如客戶有要求,請按客戶要求包裝出貨)
5. 載帶前面留10PCS空格,後面留10PCS空格

RoHS Compliant

TOLERANCES ARE

MORETHANALL
PCB CONNECTORS
Cable ASSEMBLIES
煜倫股份有限公司

DRAWING BY CY

CHECKED BY GENIUS

UNIT / mm

SCALE 1 : 1

DATE

SIZE A4

PPOJECTION

Up to 5 ±0.2
Above 5 ~ 15 ±0.3
Above 15 ~ 30 ±0.4
Above 30 ~ 50 ±0.5
Angle ±0.3°

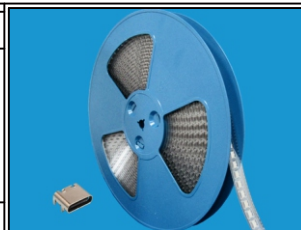

ORDER INFORMATION

USB-SWMM8686XR-24C06-LF
SERIES | T | LEADFREE
06 WAY
24 PIN C TYPE
REEL
NON SPRING
METAL FOOT 8.64mm
FEMALE
90°SMT

DESCRIPTION: PACKING

www.morethanall.com