

MATING DIAGRAM
SCALE 2 : 1

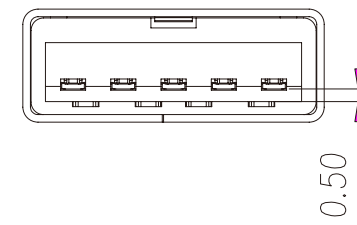
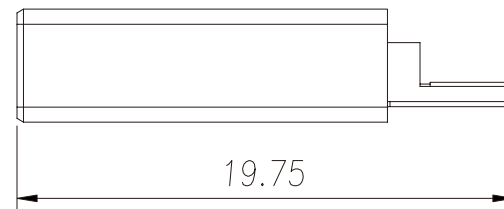
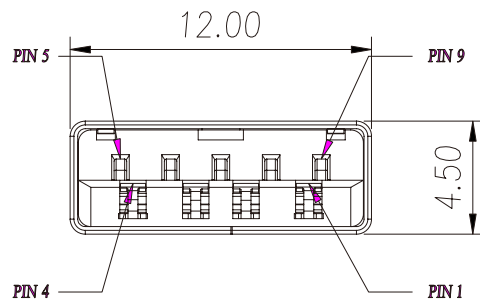

NOTE:

1. MATERIAL
 - .HOUSING : GLASS FILLED HEAT-RESISTED RESIN,UL94V-0.
 - .SPACER : GLASS FILLED HEAT-RESISTED RESIN,UL94V-0.
 - .TERMINAL : COPPER ALLOY.
 - .SHIELD : COPPER ALLOY
2. PLATING
 - TERMINAL : <CONTACT AREA> GOLD 30u".
 - <SOLDER TAIL AREA> GOLD FLASH.
 - <UNDER-PLATING> NICKEL.
 - SHELL PLATING: NICKEL
3. MECHANICAL CHARACTERISTICS:
 - .INSERTION FORCE:35N(MAX)
 - .EXTROCTION FORCE:8N(MIN) AFTER DURABILITY CYCLES
 - .DURABILITY CYCLE:1500 CYCLES;
4. ELECTRICAL CHARACTERISTICS:
 - .CURRENT RATING: 1.5A;
 - .VOLTAGE RATING: 30VAC (R.M.S.);
 - .CONTACT RESISTANCE:30m OHMS MAX;
 - .INSULATION RESISTANCE.
 - a:UNMATED:100M OHMS MIN.
 - b:MATED:100M OHMS MIN .
 - .DIELECTRIC WITHSTANDING VOLTAGE:100V AC/1MINUTE
 - .OPERATING TEMPERATURE:-55°C ~ +85°C
 - .STORAGE TEMPERATURE:-40°C ~ +60°C.
 - .OPERATION /STORAGE HUMIDITY:95% OR LESS.
5. ORDER INFORMATION:

RoHS Compliant

TOLERANCES ARE

MORETHANALL
PCB CONNECTORS
Cable ASSEMBLIES

DRAWING BY CY
CHECKED BY GENIUS
UNIT / mm SCALE 1 : 1
DATE

X. ±
.X ±
.XX ±
.XXX ±
ANG ±



ORDER INFORMATION

USB-PMBL-9A-LF
SERIES | | LEADFREE
| | 9 PIN A TYPE
| BLUE
| MOLDING
MALE

煜倫股份有限公司

www.morethanall.com

SIZE A4 PROJECTION

DESCRIPTION: USB 9PIN(M) 3.0短版