

NOTES:

1. MATERIAL:  
HOUSING: HIGH TEMPERATURE THERMO PLASTIC UL94V-0  
TERMINAL: COPPER ALLOY  
SOLDER PEG: COPPER ALLOY
2. FINISH:  
TERMINAL:  
CONTACT AREA: SEE CHARTS  
SOLDERING AREA: SEE CHARTS  
UNDER PL.: NICKEL PL. 50 μ" THK MIN.
3. THIS PRODUCT DOESN'T CONTAIN ENVIRONMENTAL HAZARDOUS PER DIRECTIVE 2002/95/EC FOR RoHS COMPLIANT.

RoHS Compliant

TOLERANCES ARE

**MORETHANALL**  
PCB CONNECTORS  
Cable ASSEMBLIES

DRAWING BY CY

CHECKED BY GENIUS

UNIT / mm

SCALE 1:1

DATE

SIZE A4

PJECTION

X, ±  
.X ±  
.XX ±  
.XXX ±  
ANG ±

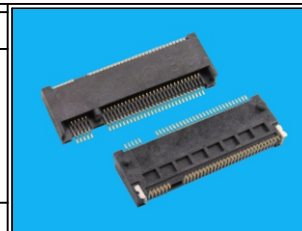

ORDER INFORMATION

NGFF-W32-1156-LF  
SERIES | LEADFREE  
| 11+56 WAY  
| HIGH 3.2mm  
| 90°SMT

煜倫股份有限公司

www.morethanall.com

DESCRIPTION:

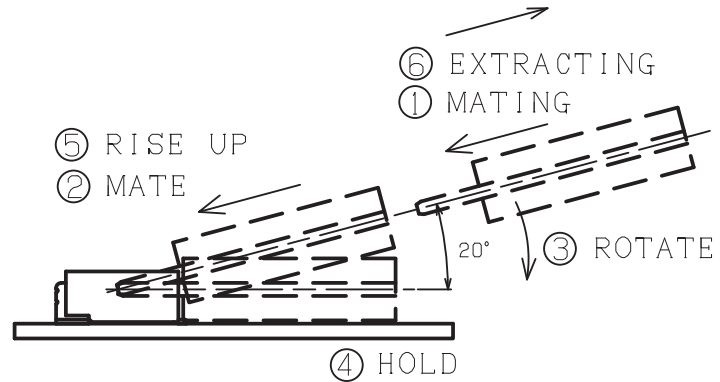
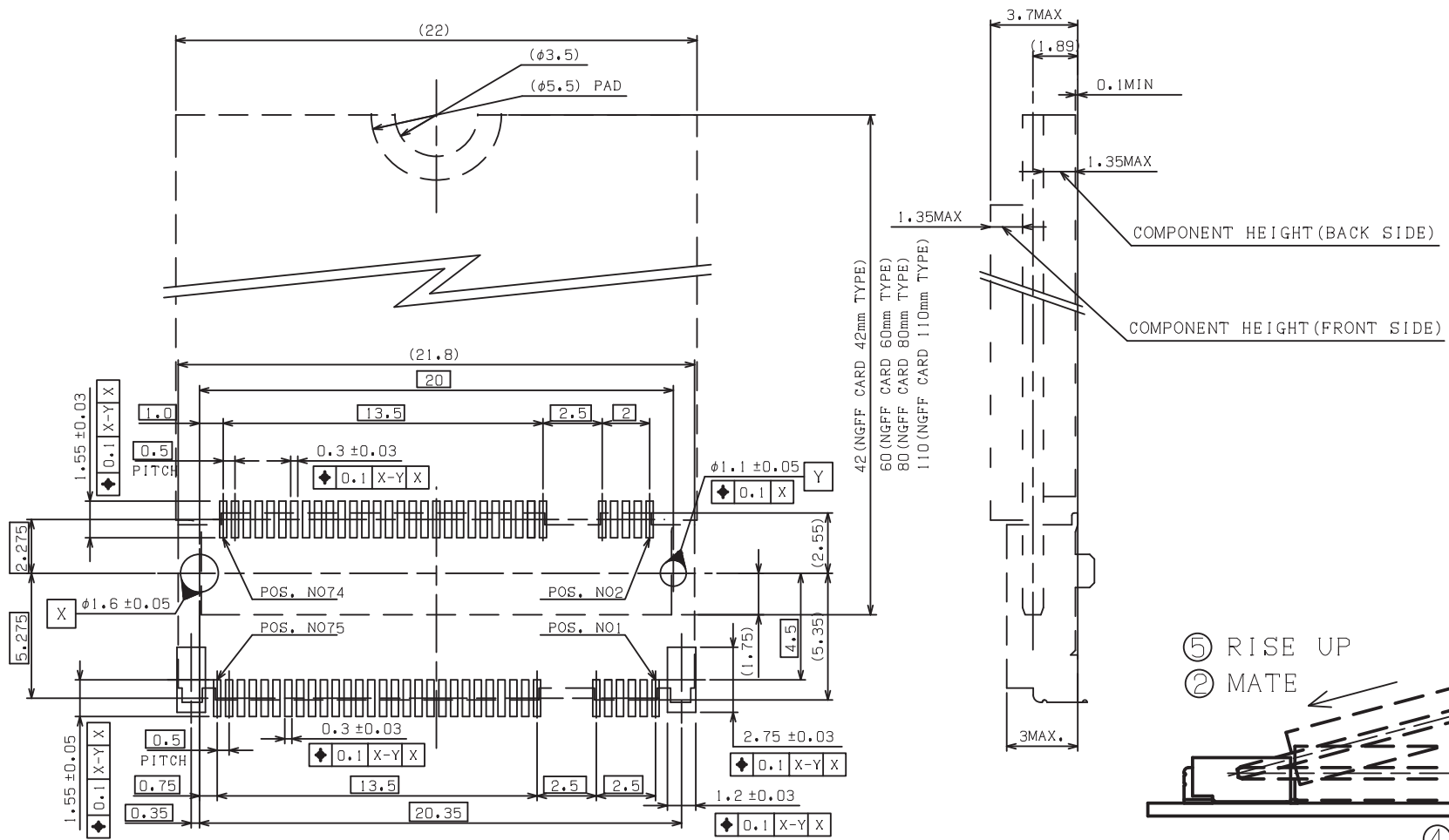

KEY ID "B"  
RECOMMENDED P.C.B. BOARD LAYOUT

**RoHS Compliant**

TOLERANCES ARE



煜倫股份有限公司

www.morethanall.com

DRAWING BY CY

CHECKED BY GENIUS

UNIT / mm SCALE 1 : 1

DATE

SIZE A4

X, ±  
.X ±  
.XX ±  
.XXX ±  
ANG ±

PJECTION

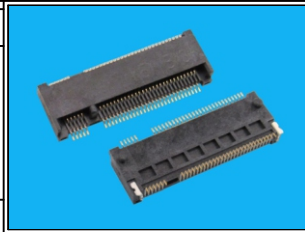

ORDER INFORMATION

NGFF-W32-1156-LF

SERIES | LEADFREE  
11+56 WAY  
HIGH 3.2mm  
90°SMT

DESCRIPTION:

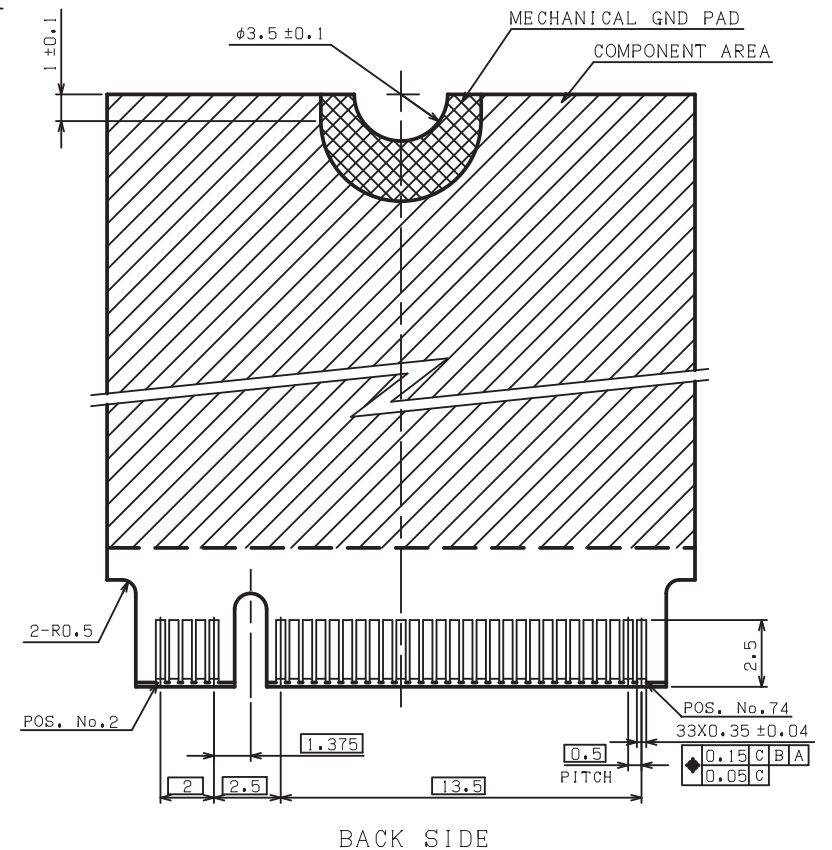
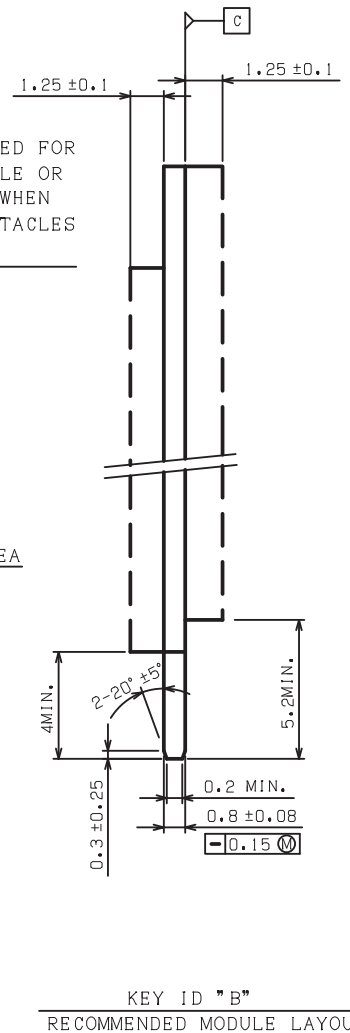
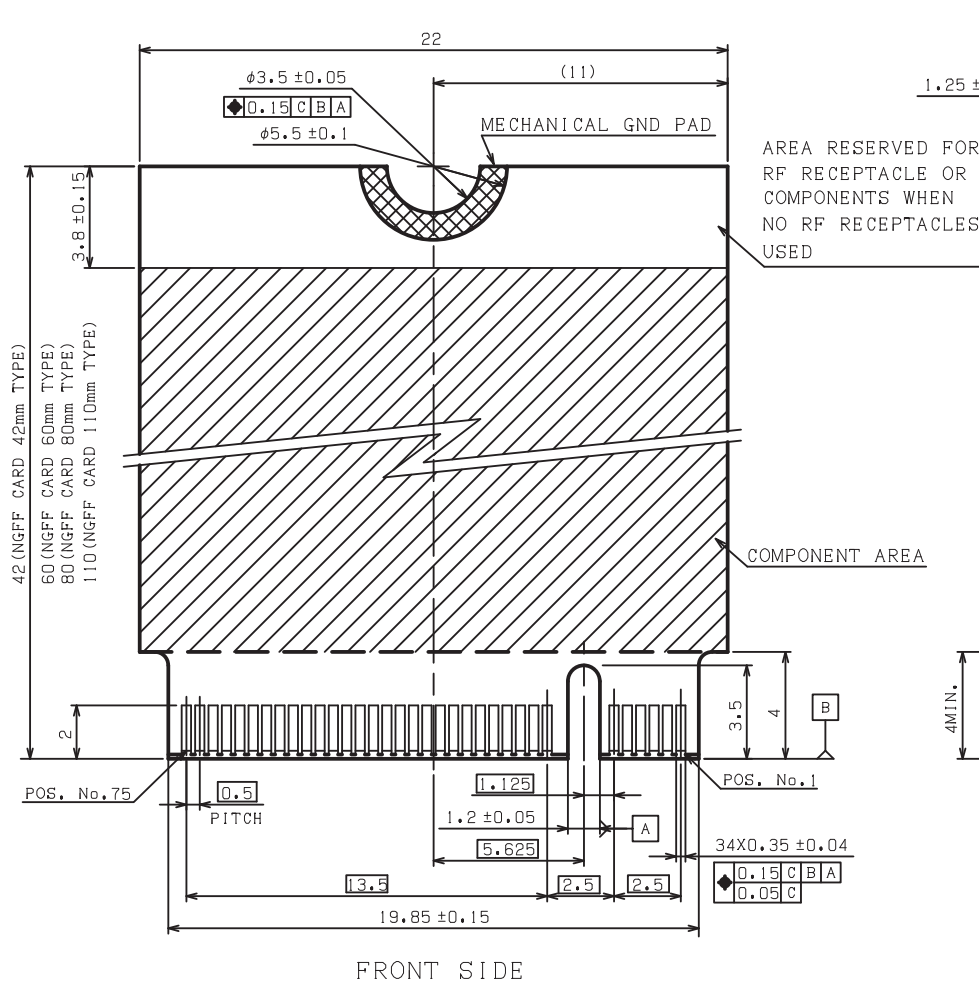

RoHS Compliant

TOLERANCES ARE

**MORETHANALL**  
PCB CONNECTORS  
Cable ASSEMBLIES

DRAWING BY CY  
CHECKED BY GENIUS  
UNIT / mm SCALE 1 : 1  
DATE

X. ±  
.X ±  
.XX ±  
.XXX ±  
ANG ±

煜倫股份有限公司

www.morethanall.com

SIZE A4

PJECTION

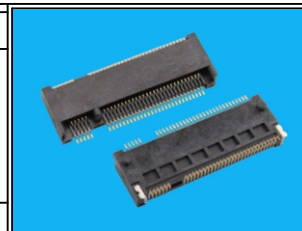

ORDER INFORMATION

NGFF-W32-1156-LF  
SERIES | LEADFREE  
11+56 WAY  
HIGH 3.2mm  
90°SMT

DESCRIPTION: