

Material:

- Item 1 Insulating body Thermoplastic (UL94V-0)
- Item 2 Terminal screw Steel Zinc plating "-" slot type
- Item 3 Terminal body Brass, Ni plated
- Item 4 Contact on entry pin Brass, Tin plated
- Item 5 Contact on back pin Brass, Tin plated

Electrical

- Voltage rating: 300V
- Current rating: 10A
- Torque(Lb-In): 3.5
- Screw: M2.5
- Wrie range:
- SOLID WIRE(AWG): 16-26
- Stranded wire(AWG): 16-26
- Wire strip length: 6~7mm
- Withstanding Voltage:1.6kv
- Operating temperature: -30° C to +105° C
- Soldering reliability: 250° C ±10° C/5 Sec

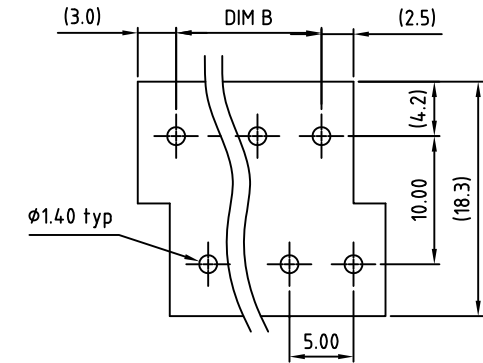
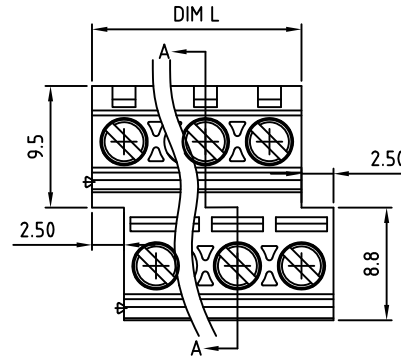

P.C.B. LAYOUT

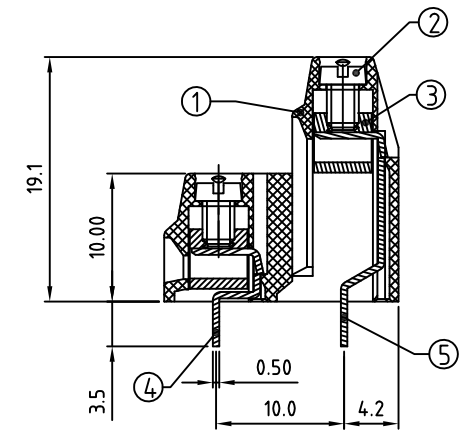
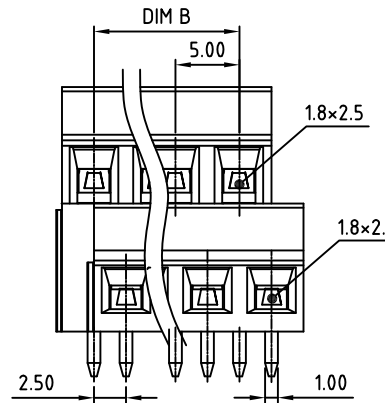

SECTION A-A

Poles	02	03	04	05	06	07	08	09	10	11	12	13
Dim L	10.00	15.00	20.00	25.00	30.00	35.00	40.00	45.00	50.00	55.00	60.00	65.00
Dim B	5.00	10.00	15.00	20.00	25.00	30.00	35.00	40.00	45.00	50.00	55.00	60.00
TOL	±0.15				±0.25				±0.35			
Poles	14	15	16	17	18	19	20	21	22	23	24	
Dim L	70.00	75.00	80.00	85.00	90.00	95.00	100.0	105.0	110.0	115.0	120.0	
Dim B	65.00	70.00	75.00	80.00	85.00	90.00	95.00	100.0	105.0	110.0	115.0	
TOL	±0.35				±0.45							

RoHS Compliant

TOLERANCES ARE



煜倫股份有限公司

www.morethanall.com

DRAWING BY CY

CHECKED BY GENIUS

UNIT / mm SCALE 1 : 1

DATE

SIZE A4

PPOJECTION

X, ±
.X ±
.XX ±
.XXX ±
ANG ±



ORDER INFORMATION

TBH050B1-D10R-xx-LF

SERIES

DIP 180°

LEADFREE
02 PER ROW:04 PIN
24 PER ROW:48 PIN
R TYPE FOOT
HIGH 10.0mm

DESCRIPTION: